



درس شناسایی های ژئوتکنیکی زمین

حفاری دورانی

Rotary Drilling

علی فاخر



دستگاه حفاری

تراکتور



درس شناسایی های ژئوتکنیکی زمین
علی فاخر

دستگاه حفاری
دورانی سوار بر
تراکتور

2



دانشگاه

درس شناسایی های ژئوتکنیکی زمین
علی فاخر

دستگاه حفاری
دورانی سوار بر
تراکتور

3



درس شناسایی های ژئوتکنیکی زمین
علی فاخر

دستگاه
حفاری
دورانی سوار
بر تریلر

4

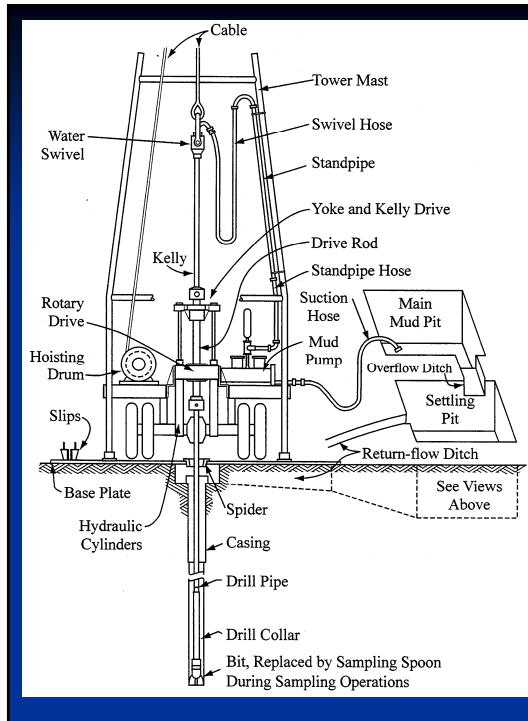

دستگاه حفاری دورانی سوار بر تریلر یا کامیون

5



درس شناسایی های ژئوتکنیکی زمین
علی فاخر

دستگاه حفاری دورانی سوار بر شاسی مستقل با چرخ رنجیری



6



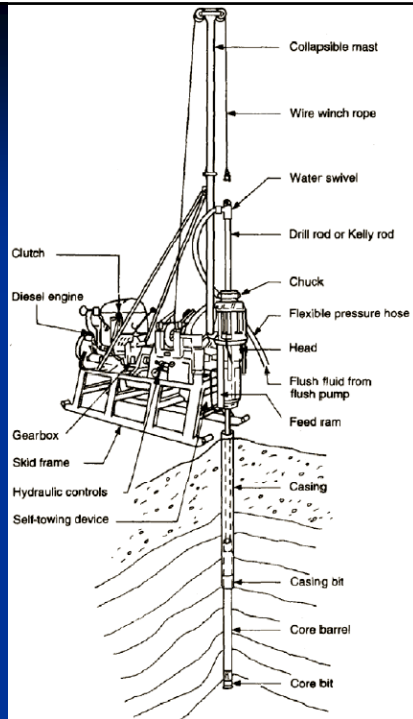

دستگاه حفاری دورانی مستقر بر زمین



دستگاه حفاری دورانی ثابت
(با قابلیت حفاری مایل)





درس شناسایی های ژئوتکنیکی زمین
علی فاخر

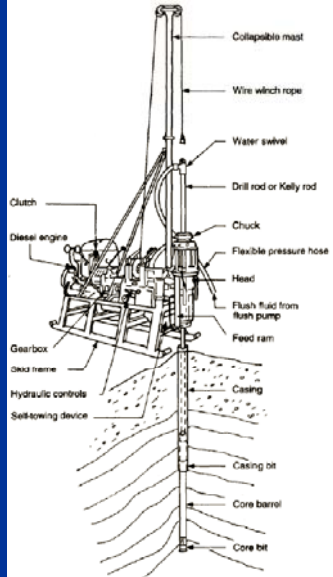

اجزای دستگاه های حفاری دورانی

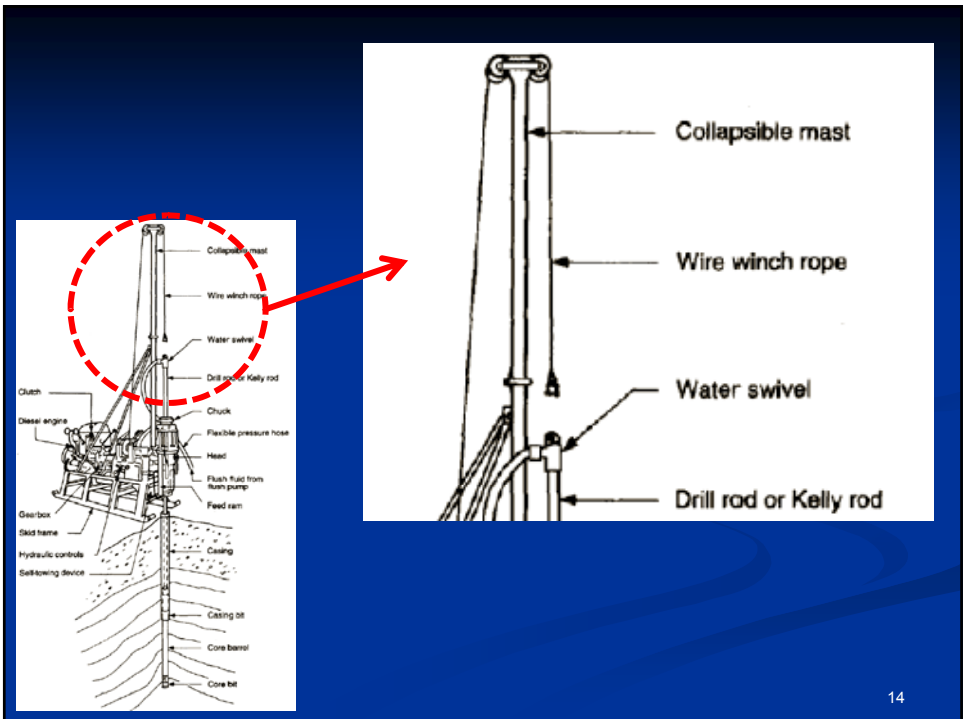

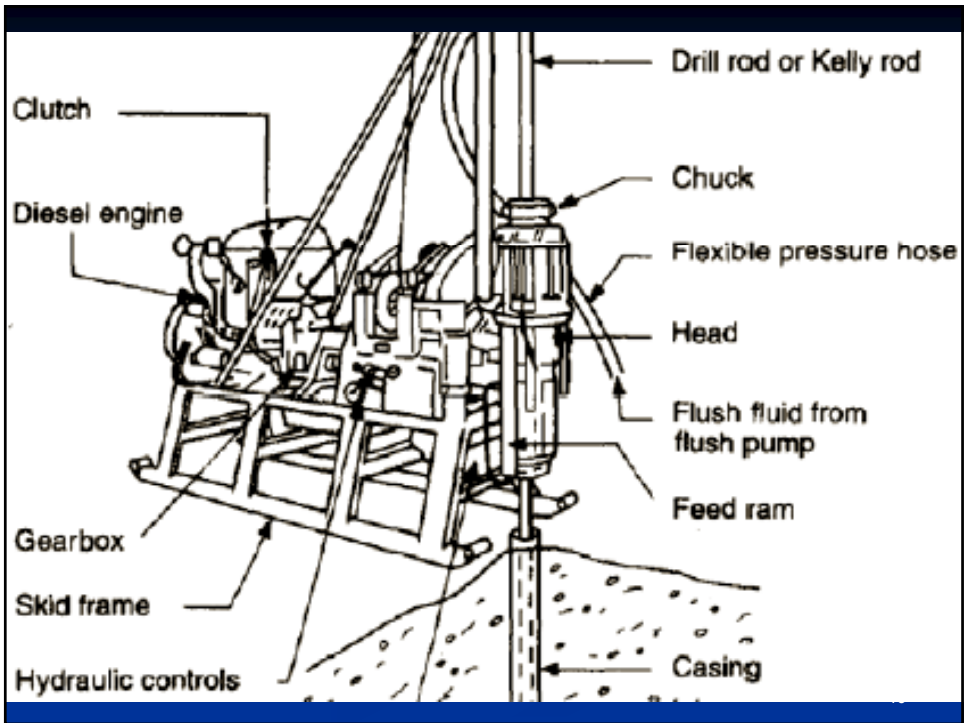
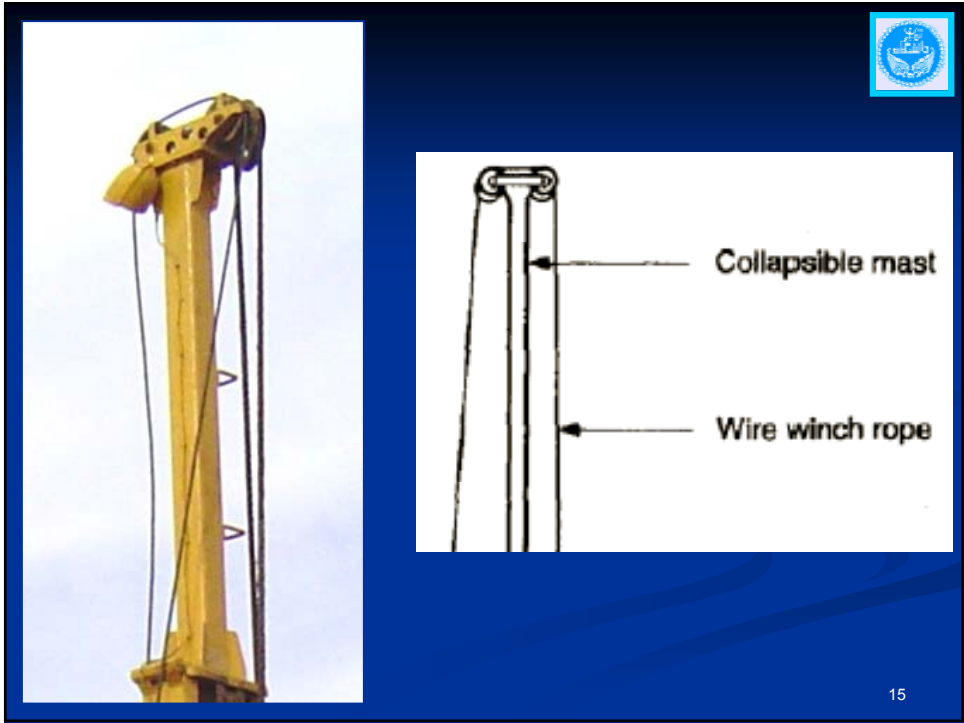

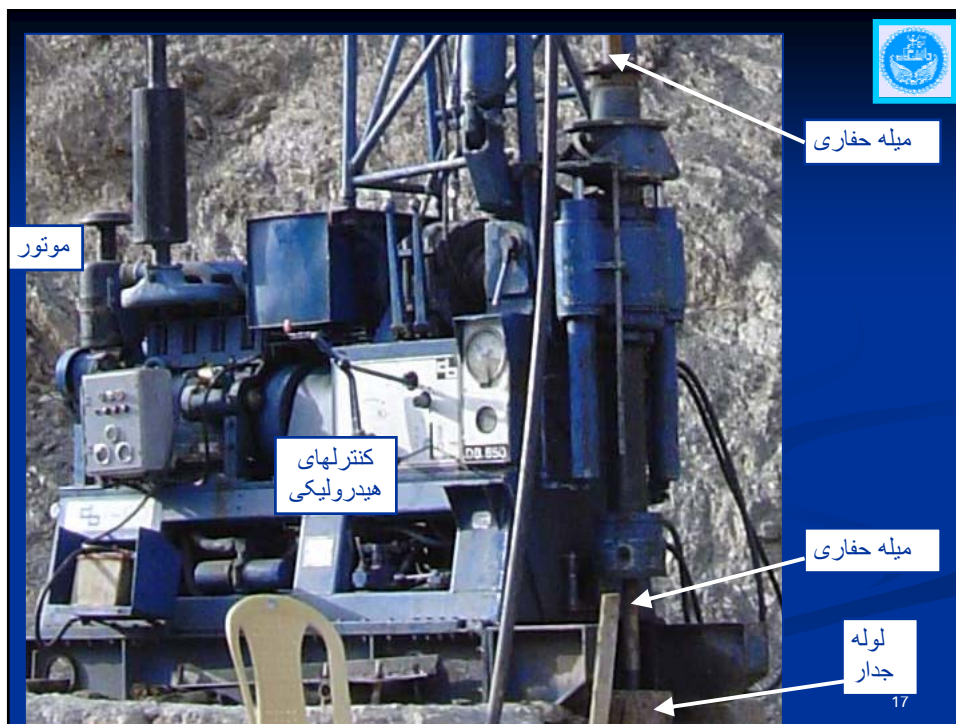

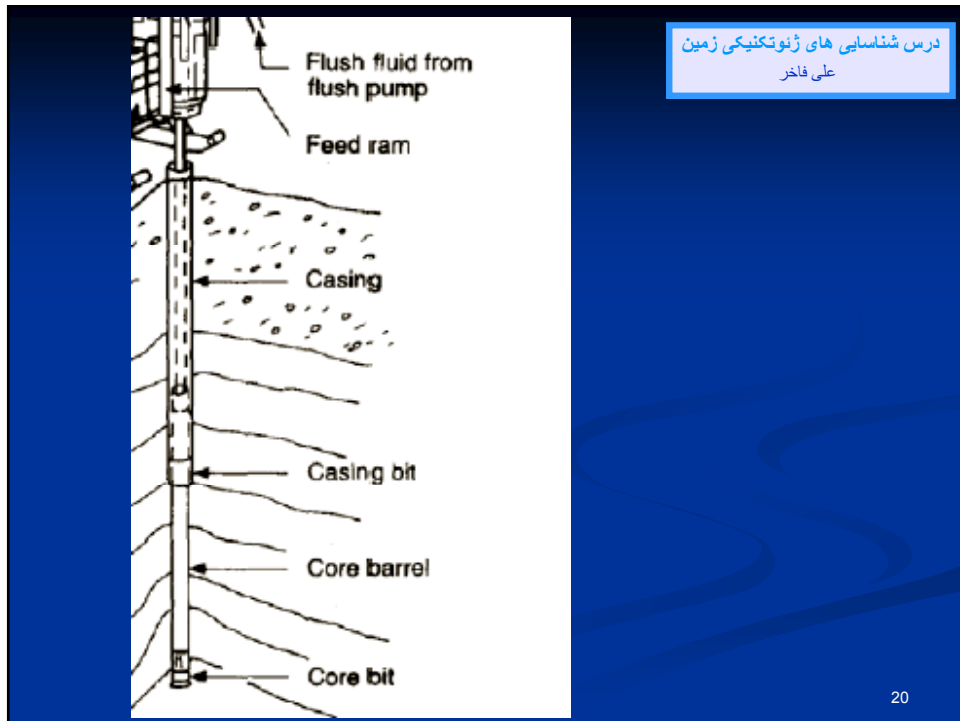
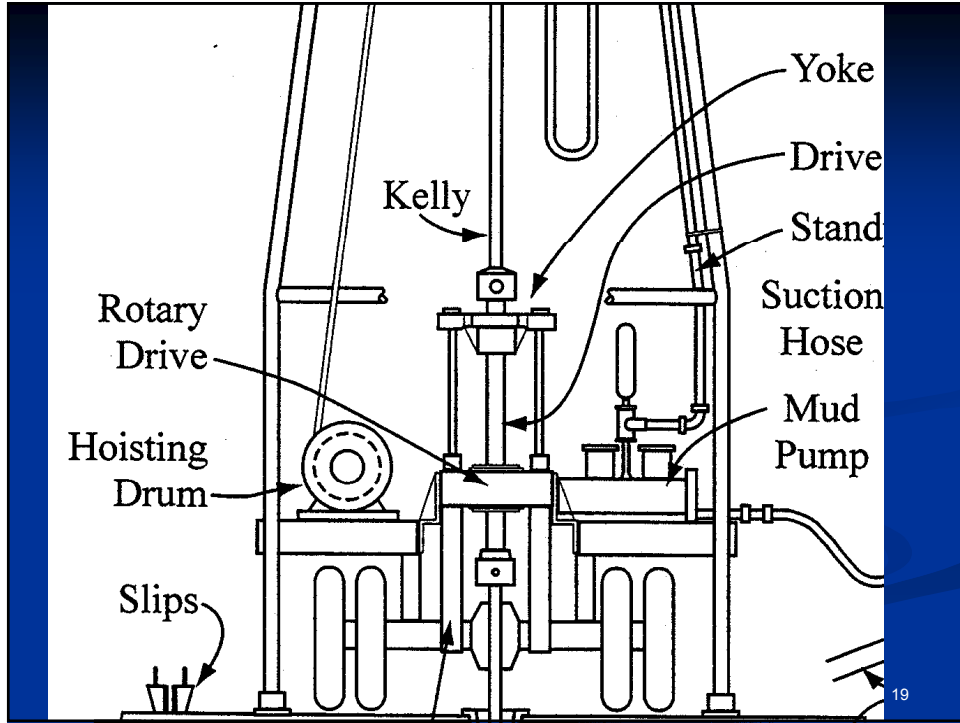

درس شناسایی های ژئوتکنیکی زمین
علی فاخر



درس شناسایی های ژئوتکنیکی زمین
علی فاخر

Casing

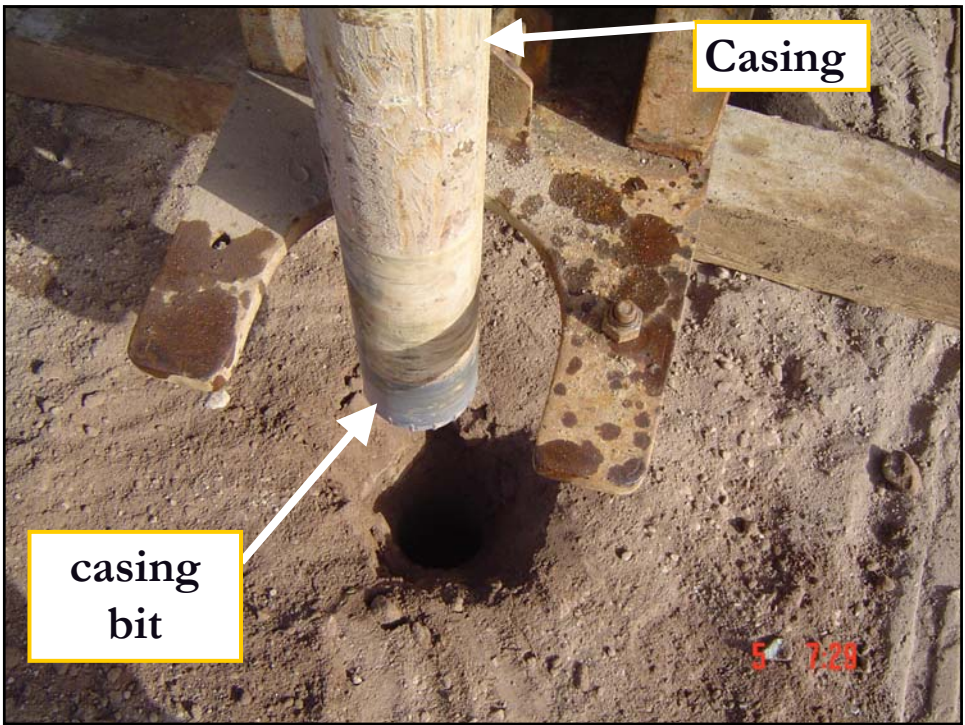



Casing & driving shoe

23

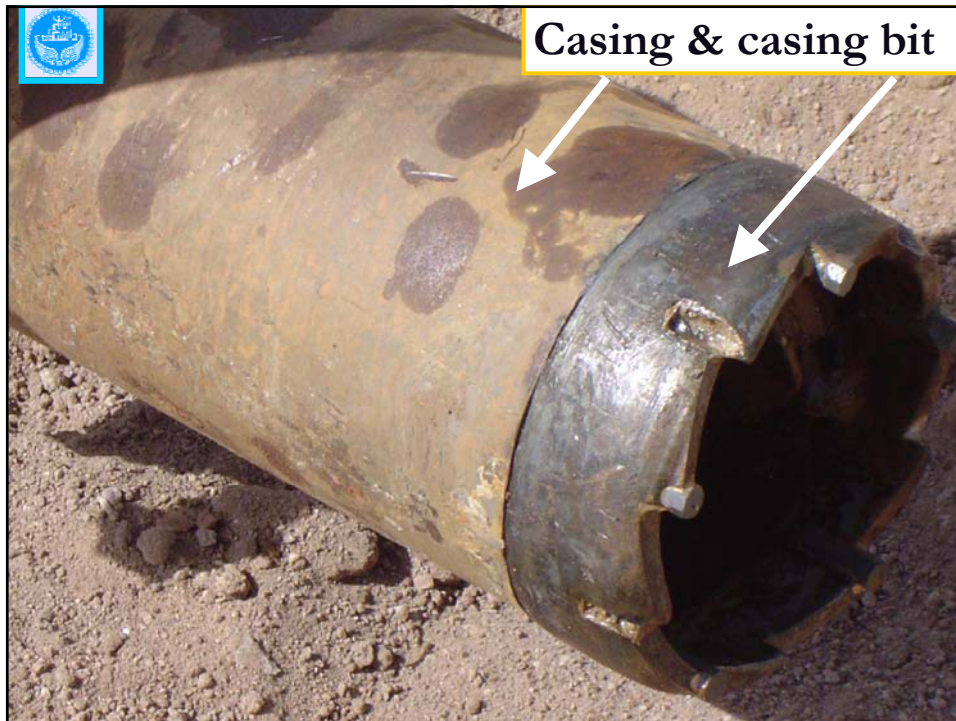







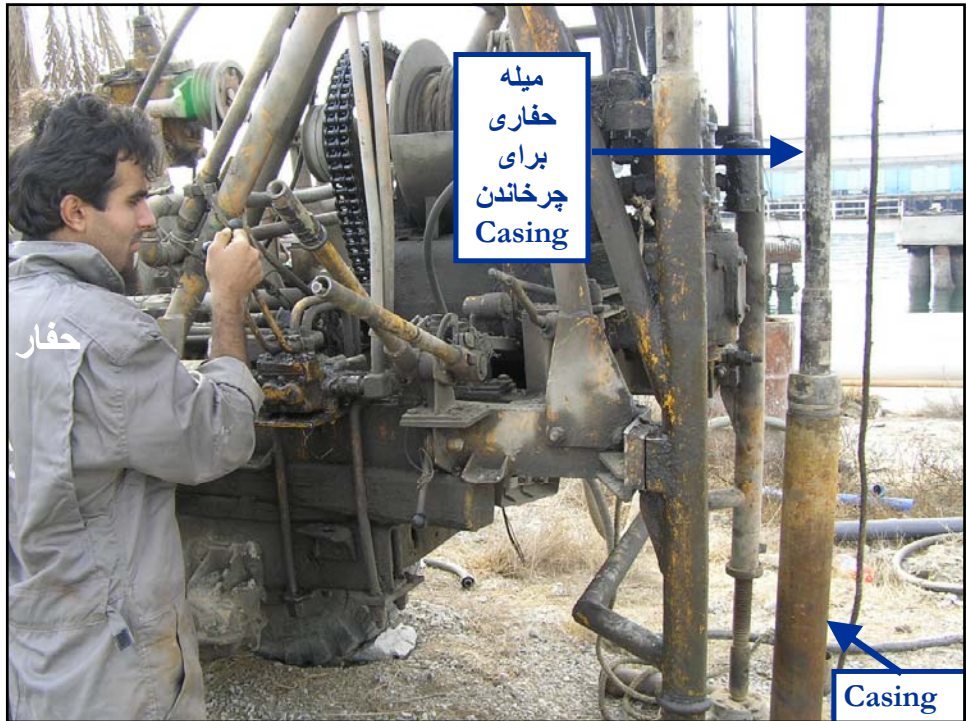



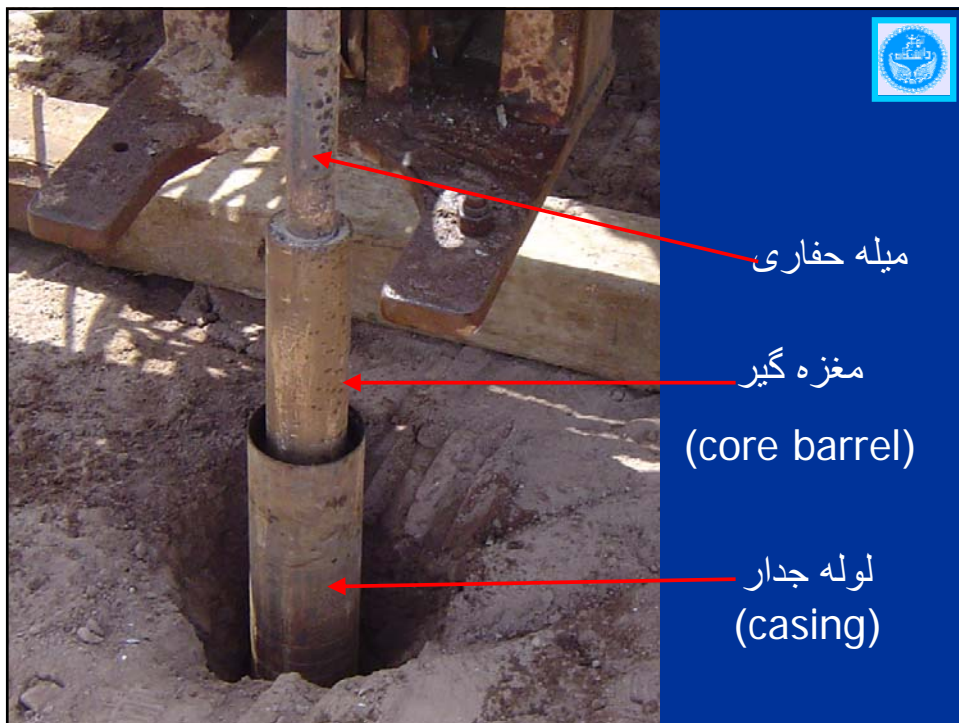

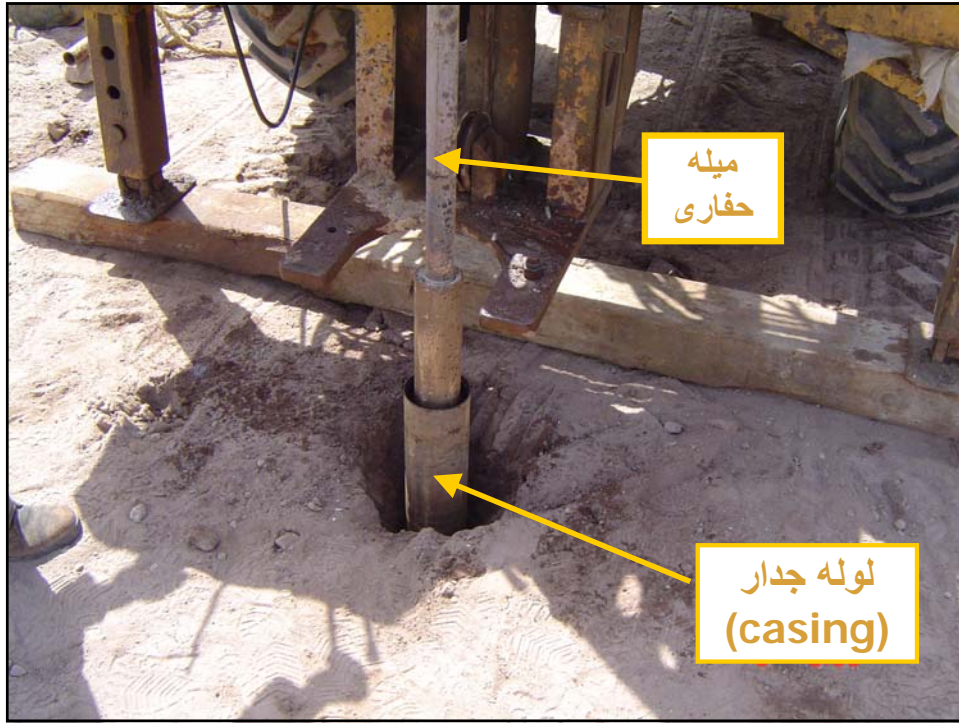





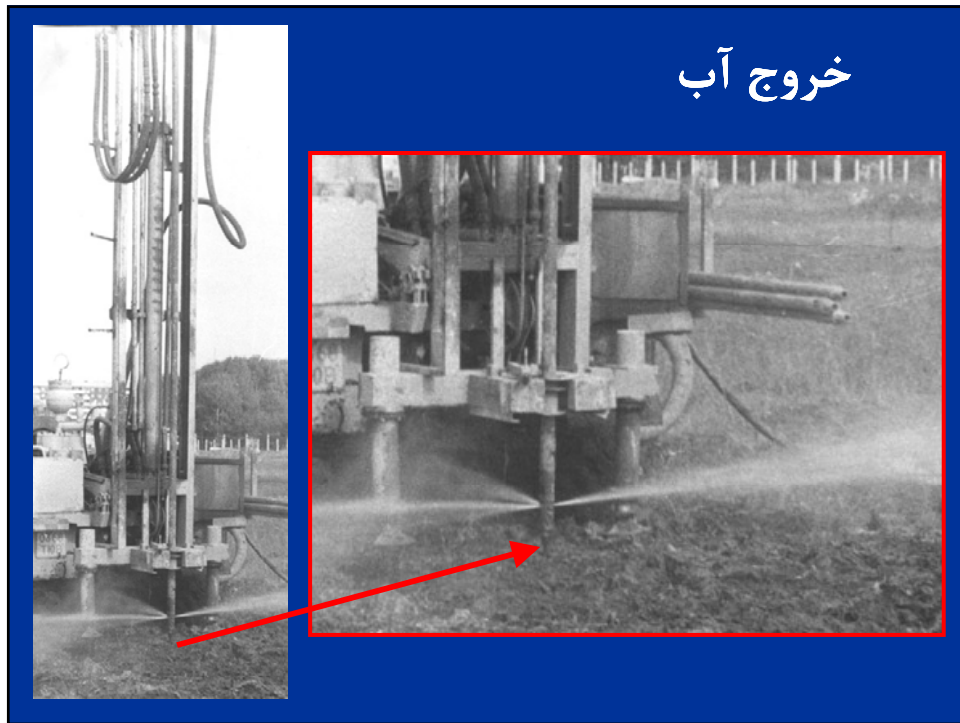

خروج سیال
(آب) حفاری



Drill fluid discharge

خروج سیال حفاری (آب)

46

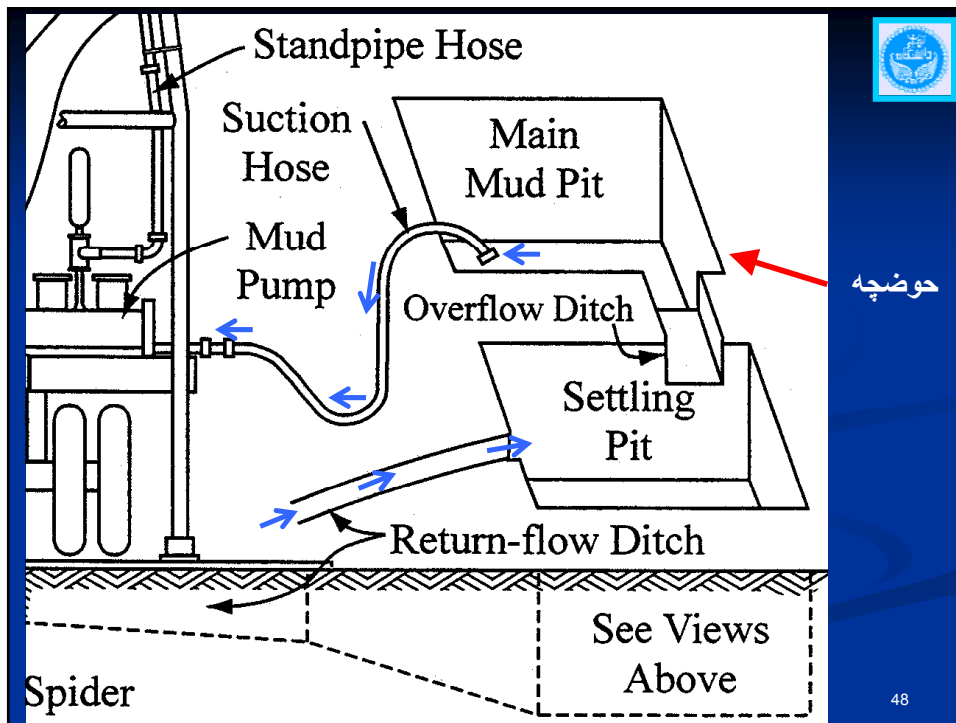
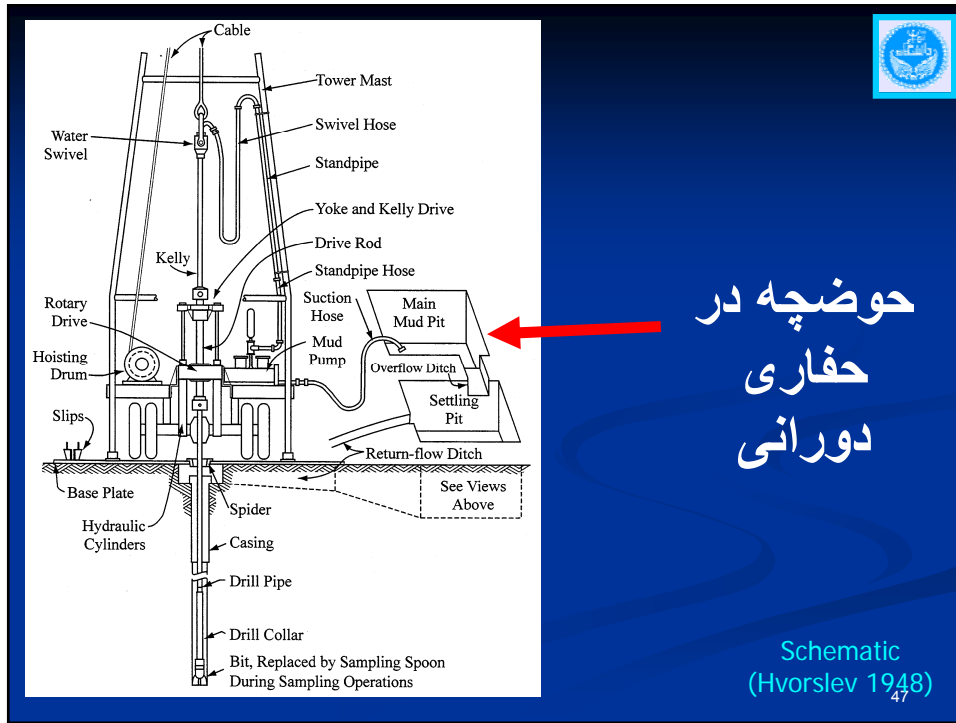



mud tank

49



Fluid cuttings catch screen

50



51



52

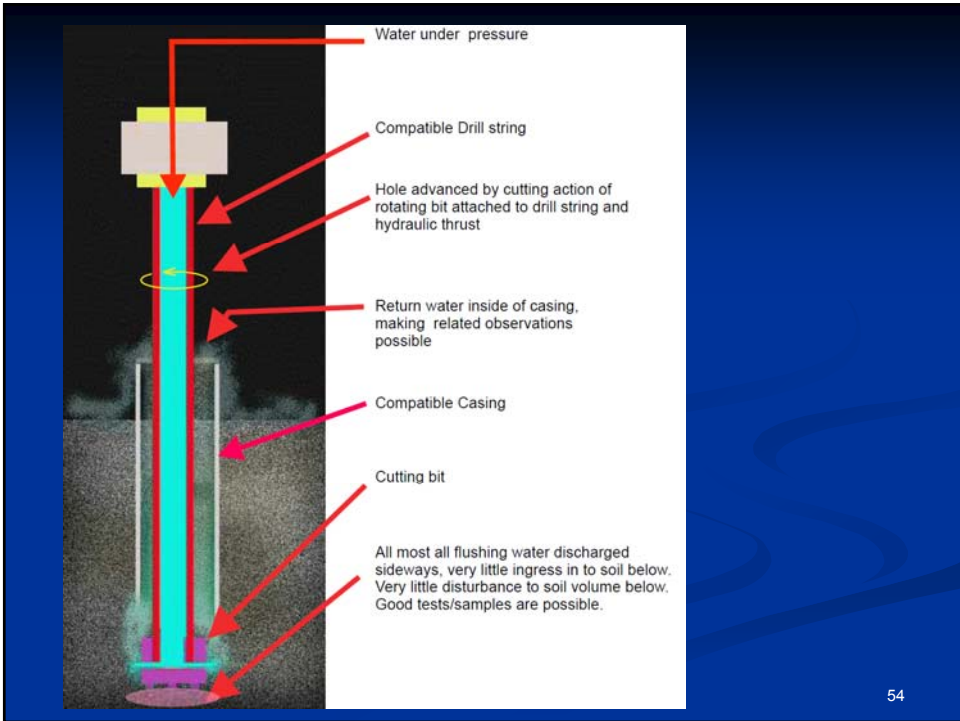
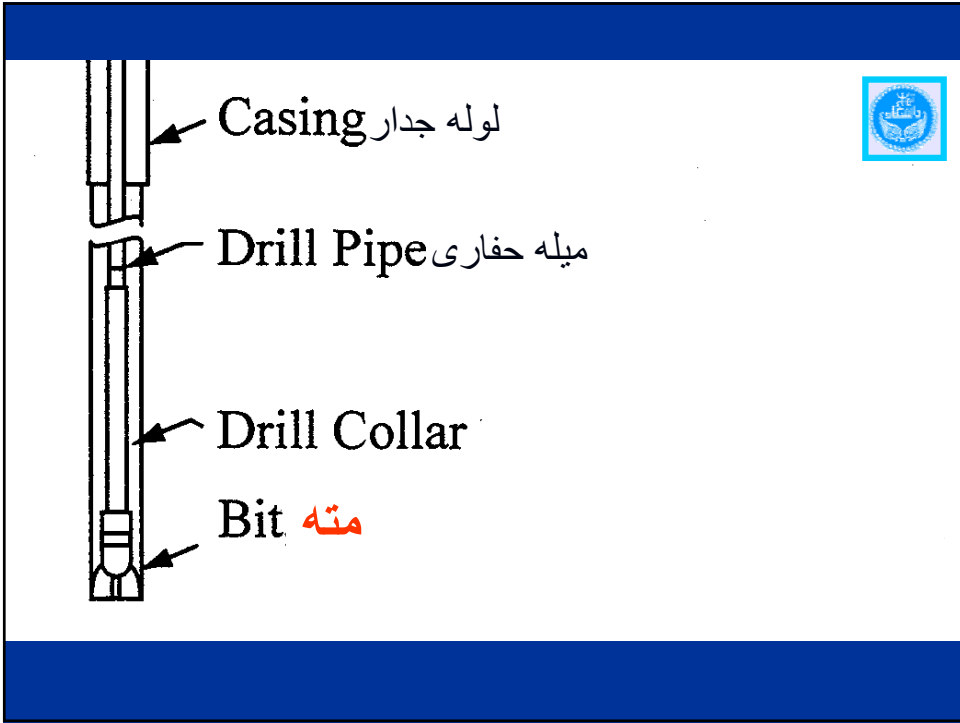

Hole advanced by cutting bit attached to the bottom of drill string and hydraulic thrust with cuttings transported upwards by drilling fluid/water. Use compatible casings and rods, drag and cutting bits cutting bits varying with soil types. Almost all water discharged sideways

55

Rotary Wash Borings



- Drilling bits:
 - Drag bits for clays
 - Roller bits for sands



Drag, Roller, and Diamond Bit Types



Drag, Roller, and Diamond Bit Types



Tungsten Insert
Drag Bit

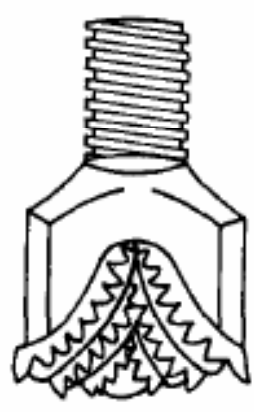

Roller Rock Bit or
Tricone Bit

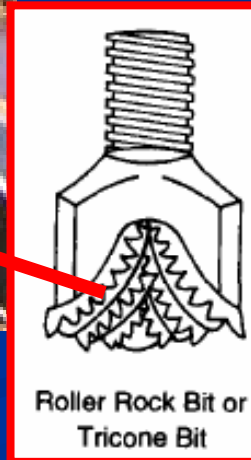

59

Noncoring Bit



Rock Coring Bit





Wireline Rig



موفق باشید